

# Memory Efficient LUT Based Address Generator for OFDM-WiMAX De-Interleaver

Bijoy Kumar Upadhyaya<sup>1</sup>, Pranab Kumar Goswami<sup>1</sup>, and Salil Kumar Sanyal<sup>2</sup>

<sup>1</sup>Department of Electronics & Telecommunication, Tripura Institute of Technology, Narsingarh, Tripura, India

<sup>2</sup>Department of Electronics & Telecommunication, Jadavpur University, Kolkata, India

Email: bku.agt@gmail.com, pranab.picklu.com@gmail.com, s\_sanyal@ieee.org

**Abstract**—In this paper, a memory efficient Look-up Table (LUT) based address generator for the de-interleaver used in OFDM-WiMAXtransceiver is proposed. The relationships between various address LUTs implementing different interleaver / de-interleaver depths within a modulation scheme have been exploited to model the proposed address generator. The proposed design shows 81.25% saving of memory blocks in comparison with conventional technique. Hardware structure of the address generator is developed and is converted into a VHDL model using Xilinx Integrated Software Environment (ISE). Simulation results obtained using ModelSim XE-III verifies the functionality of the proposed design. Comparative study of FPGA implementation results of the design on two different platforms is presented. Performance improvement of approximately 30% in terms of maximum operating frequency over a recent work is also obtained.

**Index Terms**—address generator, de-interleaver, FPGA, LUT, OFDM, VHDL, WiMAX

## I. INTRODUCTION

Broadband Wireless Access (BWA) has become a popular choice over Digital Subscriber Line (DSL) or cable modem for internet access. Worldwide Interoperability for Microwave Access (WiMAX) is based on IEEE 802.16 standard for BWA system. The fixed BWA (FBWA) is based on IEEE 802.16-2004 and operates in the frequency band of 2 to 11GHz [1]. Amendment IEEE 802.16e adds mobility support to IEEE 802.16 and defines standard for mobile BWA (MBWA) in the frequency band 2 to 6GHz. Typical data rate in IEEE 802.16e is 5Mbps with bandwidth 1.25 to 20 MHz. Both IEEE 802.16-2004 and IEEE 802.16e permit Non Line of Sight (NLOS) connectivity [2].

Orthogonal Frequency Division Multiplexing (OFDM) [2] technique offers promising solution that has gained tremendous research interest in recent years due to its high transmission capability and alleviating the adverse effects of Inter Symbol Interference (ISI) and Inter Channel Interference (ICI) ability. In an OFDM system, the data is divided into multiple parallel sub-streams at a reduced data rate, and each is modulated and transmitted on a separate orthogonal subcarrier. This increases

symbol duration and improves system robustness. OFDM is achieved by providing multiplexing on users' data streams on both uplink and downlink transmissions. OFDM is the fundamental building block of the IEEE 802.16 standard.

Interleaving plays an important role in improving the performance of Forward Error Correcting (FEC) codes in terms of bit error rate. Interleaving is a process to rearrange code symbols so as to spread burst of errors into random like errors and thereafter FEC techniques can be applied to correct them. Block interleaving is one of the widely used techniques for interleaving in which the bits received from the encoder are stored row wise in the interleaver's memory and read column wise. WiMAX uses a special type of block interleaver in which the channelinterleaver depth and pattern varies based on code rate and modulation type.

In this paper, we propose a novel technique to implement the address generator used in OFDM-WiMAX de-interleaver. The conventional Look-Up Table (LUT) based technique for address generation has been re-designed to use the memory blocks efficiently. During this work, it has been observed that within a modulation scheme the address LUT of a smaller interleaver depth is the subset of the address LUT of larger interleaver depth in WiMAX de-interleaver address generator. This relationship between the address LUTs is used to propose a novel memory efficient LUT based address generator for WiMAX de-interleaver. The proposed scheme shows 81.25 % improvement in terms of saving memory blocks. A hardware structure for the proposed LUT based de-interleaver address generator is designed and is transformed into a VHDL model using Xilinx Integrated Software Environment (ISE). The model is then implemented on two reconfigurable platforms and comparative analysis in term of FPGA resources / parameters between the two is also presented. Based on the equivalence drawn using [3], our implementation shows betterment of approximately 30% over [4] in terms of maximum operating frequency.

## II. SYSTEM DESCRIPTION

The system level overview of IEEE 802.16e based WiMAX system is described in Fig. 1. In this system, the input binary data stream obtained from a source is randomized to prevent a long sequence of 1s and 0s,

Manuscript received October 14, 2013, revised January 23, 2013.

This research is supported by The Institution of Engineer (India), Kolkata, India. Project id is UG2013007.

which will cause timing recovery problem at the receiver. Pseudo Random Binary Sequence (PRBS) is used in which randomization is done by modulo 2 addition of the data with the output of the PRBS itself [5]. The randomized data bits are thereafter encoded using Reed Solomon (RS) encoder followed by Convolutional Coder (CC). The former is suitable for correction of burst type of error whereas the later is for random error. After RS-CC encoding all encoded data bits shall be interleaved by a special type of block interleaver. Thereafter, data passes through the mapper block in which modulation takes place. The resulting data symbols are used to construct one OFDM symbol by performing Inverse Fast Fourier Transform (IFFT).

In the receiver, inverse blocks are applied which perform DFT, de-mapping, de-interleaving, decoding and de-randomizing operations in sequential manner to get back the original data sequence.

### III. INTERLEAVING / DE-INTERLEAVING IN WiMAX

The WiMAX block interleaver/de-interleaver exploits different Interleaver depths ( $N_{cbps}$ ) to incorporate various code rates and modulation schemes and is described in standard document for IEEE 802.16e [6]. The Encoded data bits received from CC are interleaved by a block interleaver using two step processes [7]. The first step ensures that the adjacent coded bits are mapped onto nonadjacent subcarriers, which provides frequency diversity and improves the performance of the decoder. The second step ensures that adjacent coded bits are alternately mapped to less and more significant bits of the modulation constellation thus avoiding long runs of lowly reliable bits.

The de-interleaver, which performs the inverse operation, is also defined by another two permutations and is described in [4].

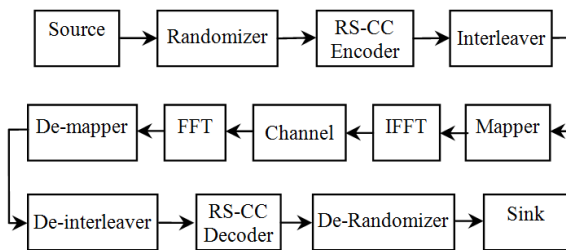

Figure 1. Block diagram of WiMAX transceiver

### IV. MODELING MEMORY IN FPGA

Static Random Access Memory (SRAM) based FPGAs [8] offer internal (embedded) storage for potential applications like local storage, FIFO, data buffers, stack, large LUT etc. In Xilinx FPGA, these internal storages are called Block RAM (BRAM) [9]. Table I and Fig. 2 list all the interface signals of a single port BRAM and their directions. In our experimentation, Xilinx Spartan-3/Spartan-3AN FPGA (device XC3S1400AN) [8] having 16/32 nos. of 18KB (16KB data and 2KB parity) single port BRAM block is used. Out of these, 3 BRAM blocks

are used to store the address LUTs for three different modulation schemes of WiMAX de-interleaver address generator.

## V. HARDWARE MODEL OF INTERLEAVER

### A. Methodology of Proposed Design

In general, design methodology of hardware interleaver is classified into two categories, LUT based and incremental address generation based. The former technique is relatively simple but consumes large logic resources, particularly memory, whereas the later involves complex design methodology but requires relatively less logic resources. In this work, the authors propose an improved design methodology to implement the LUT based address generator for WiMAX de-interleaver on reconfigurable platform. As per IEEE 802.16e standard [6],  $\frac{1}{2}$ ,  $\frac{2}{3}$  and  $\frac{3}{4}$  are the allowed code rates where as QPSK, 16-QAM and 64-QAM are the permitted modulation schemes. Accordingly, there are eight, four and four interleaver depths in QPSK, 16-QAM and 64-QAM modulation schemes respectively [7] to implement all the permissible code rates and modulation schemes. In conventional LUT based approach, to implement the de-interleaver address generator, 16 numbers of memory blocks of varying size are required to house all the interleaver addresses. During this work, a relationship between the de-interleaver memory addresses of various  $N_{cbps}$  within a modulation scheme is identified. It is found that, the memory addresses of a larger  $N_{cbps}$  encompass the same of smaller  $N_{cbps}$ . This relationship between the address LUTs is exploited to propose a memory efficient LUT based address generator for WiMAX de-interleaver. Using our proposed design, the number of memory blocks used is reduced to 3 only ensuring saving of 81.25% critical resource.

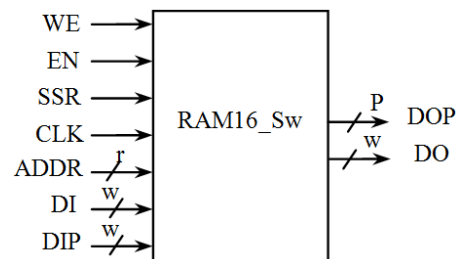

Figure 2. Single port BRAM in Xilinx Spartan-3AN FPGA

TABLE I. SINGLE PORT BRAM INTERFACE SIGNAL

Signal Description	Port Name	Direction
Data Input Bus	DI	Input
Parity Data Input Bus	DIP	Input
Data Output Bus	DO	Output
Parity Data Output	DOP	Output
Address Bus	ADDR	Input
Write Enable	WE	Input
Clock Enable	EN	Input
Synchronous Set/Rest	SSR	Input
Clock	CLK	Input

A MATLAB program is developed using (3) and (4) of [4] to determine the write addresses of the de-

interleaver for all code rates and modulation schemes. Among these addresses, first 5 rows for each modulation schemes with  $N_{cbps} = 576$ -bits are presented in Table II(a)-(c). The first 6 columns in Table II(a), describe the memory addresses of first 5 rows with  $N_{cbps} = 96$ -bits and QPSK modulation scheme. Similarly, the first 5 rows of interleaver memory addresses with  $N_{cbps} = 144$ -bits and QPSK modulation scheme are represented by the first 9 columns in Table II(a). Likewise, the addresses for other  $N_{cbps}$  with QPSK modulation scheme can be determined from the same table where the number of columns is defined as  $N_{cbps}/d$  (here  $d = 16$ ). A similar approach can be applied in Table II(b) and (c) to determine the memory addresses with various interleaver depths for 16-QAM and 64-QAM modulation schemes respectively. Pictorial representation of this relationship of memory addresses between various interleaver depths are given in Fig. 3(a)-(c).

**B. Proposed Hardware for the Address Generator**

The hardware structure of the proposed LUT based address generator for WiMAX de-interleaver is shown in Fig. 4. The complete hardware is divided into two parts: LUT address generator block and LUT block. The former consists of ROMs, multiplexers and an up counter responsible for generating the memory address (*icount*) required to read the address LUTs. The ROMs store the terminal values of each row as input and the starting values of the next row as the output. The column counter counts up to the desired column and then gets reloaded with another *preset* value representing the starting memory address of the next row from the appropriate ROM selected by *mod typ* and *code rate* signals. The contents of a ROM used to implement  $N_{cbps} = 96$  of QPSK (ROM\_00\_000) is presented in Table III. Similar content are available in other ROMs.

The later block contains the three address LUTs storing the de-interleaver addresses for the three modulation schemes. The multiplexer arrangement along with values in the *mod typ* ensures selection of proper

address LUT for a particular modulation scheme. The selected address LUT is read using *icount* and the de-interleaver addresses are made available at the *address* output line.

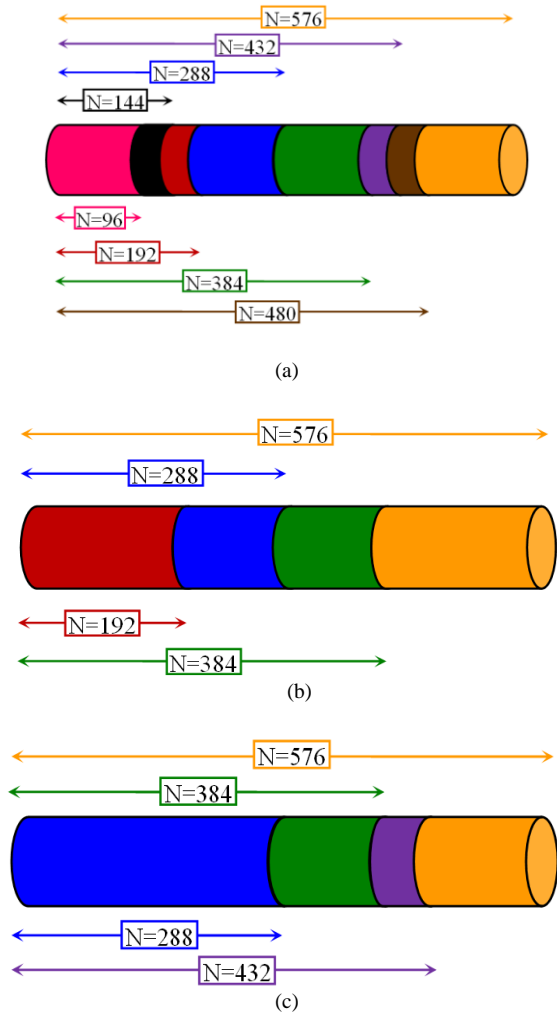

Figure 3. Relationship between de-interleaver memory address with various  $N_{cbps}$  ( $= N$ ) and a) QPSK modulation scheme. b) 16-QAM modulation scheme. c) 64-QAM modulation scheme

TABLE II(A). FIRST FIVE ROWS OF ADDRESSES FOR  $NCBPS = 576$ ,  $3/4$  CODE RATE, QPSK

0	16	32	48	64	80	96	112	128	144	160	176	192	208	224	240	256	272	288	304	320	336	352	368	384	400	416	432	448	464	480	496	512	528	544	560
1	17	33	49	65	81	97	113	129	145	161	177	193	209	225	241	257	273	289	305	321	337	353	369	385	401	417	433	449	465	481	497	513	529	545	561
2	18	34	50	66	82	98	114	130	146	162	178	194	210	226	242	258	274	290	306	322	338	354	370	386	402	418	434	450	466	482	498	514	530	546	562
3	19	35	51	67	83	99	115	131	147	163	179	195	211	227	243	259	275	291	307	323	339	355	371	387	403	419	435	451	467	483	499	515	531	547	563
4	20	36	52	68	84	100	116	132	148	164	180	196	212	228	244	260	276	292	308	324	340	356	372	388	404	420	436	452	468	484	500	516	532	548	564

TABLE II(B). FIRST FIVE ROWS OF ADDRESSES FOR  $NCBPS = 576$ ,  $3/4$  CODE RATE, 16-QAM

0	16	32	48	64	80	96	112	128	144	160	176	192	208	224	240	256	272	288	304	320	336	352	368	384	400	416	432	448	464	480	496	512	528	544	560
17	1	49	33	81	65	113	97	145	129	177	161	209	193	241	225	273	257	305	289	337	321	369	353	401	385	433	417	465	449	497	481	529	513	561	545
2	18	34	50	66	82	98	114	130	146	162	178	194	210	226	242	258	274	290	306	322	338	354	370	386	402	418	434	450	466	482	498	514	530	546	562
19	3	51	35	83	67	115	99	147	131	179	163	211	195	243	227	259	275	307	291	339	323	371	355	387	403	435	419	467	451	499	483	515	531	563	547
4	20	36	52	68	84	100	116	132	148	164	180	196	212	228	244	260	276	292	308	324	340	356	372	388	404	420	436	452	468	484	500	516	532	548	564

TABLE II(C). FIRST FIVE ROWS OF ADDRESSES FOR  $NCBPS = 576$ ,  $1/2$  CODE RATE, 64-QAM

0	16	32	48	64	80	96	112	128	144	160	176	192	208	224	240	256	272	288	304	320	336	352	368	384	400	416	432	448	464	480	496	512	528	544	560
17	33	1	65	81	49	113	129	97	161	177	145	209	225	193	257	273	241	305	321	289	353	369	337	401	417	385	449	465	433	497	513	481	545	561	529
34	2	18	82	50	66	130	98	114	178	146	162	226	194	210	274	242	258	322	290	306	370	338	354	418	386	402	466	434	450	514	482	498	562	530	546
3	19	35	51	67	83	99	115	131	147	163	179	195	211	227	243	259	275	291	307	323	339	355	371	387	403	419	435	451	467	483	499	515	531	547	563
20	36	4	68	84	52	116	132	100	164	180	148	212	228	196	260	276	244	308	324	292	356	372	340	404	420	388	452	468	436	500	516	484	548	564	532

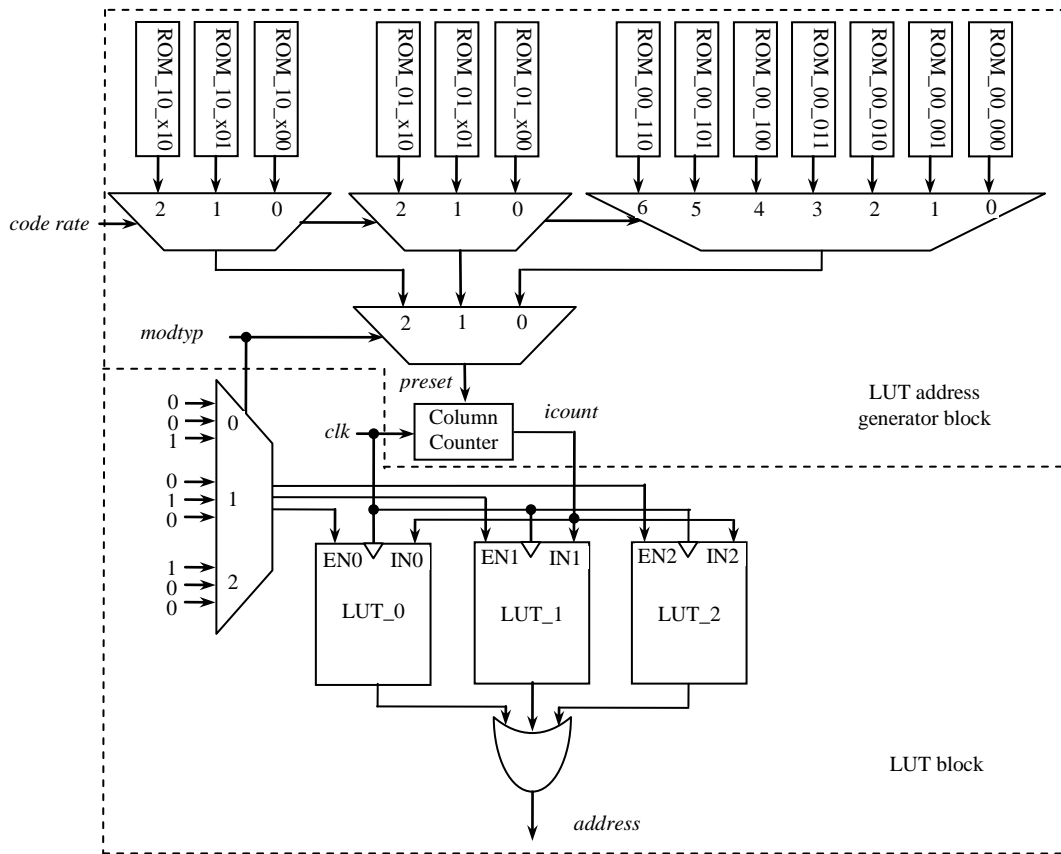

Figure 4. Detailed hardware structure of proposed address generator

VI. SIMULATION Results

The simulation result in the form of timing diagram obtained using ModelSim Xilinx Edition-III for QPSK (mod\_typ = 00) with N<sub>cbps</sub> = 144 (code\_rate = 001), is shown in Fig. 5. The captured portion shows the de-interleaver addresses generated for the first three rows and are identical with Table II(a). The authors have generated and verified addresses for all coding rates and modulation schemes however due to space limitation other results are not included.

VII. FPGA IMPLEMENTATION Results

The proposed hardware structure of de-interleaver address generator is transformed into VHDL model using Xilinx Integrated Software Environment (ISE 8.1) and is implemented on Xilinx Spartan 3 FPGA (XC3S400). Additionally, the hardware structure is also implemented on Xilinx Spartan-3AN FPGA (XC3S1400AN) using ISE 12.1. Table IV shows the device utilization summary for

both implementations. The two implementations are almost identical in terms of FPGA resource utilizations, but differ significantly in operating frequency and estimated power consumption. It is observed that the design implemented on advanced FPGA (Spartan-3AN) works faster by 30% than the other, but also consumes double amount of power. The principal advantage of our proposed technique is that it requires only 3 BRAMs of capacity 18KB instead of 16, saving 81.25% of critical FPGA internal resource.

Based on the equivalence drawn between FPGA and ASIC implementations in [3] our work is compared with that of [4] by converting the later in FPGA equivalent implementation. This comparison shows our implementation on Spartan 3 FPGA is at par with [4] in terms of operating frequency. But, the implementation on Spartan 3AN shows improvement of almost 30% over [4] as FPGA equivalent maximum frequency of the later is found to be 62.5MHz.

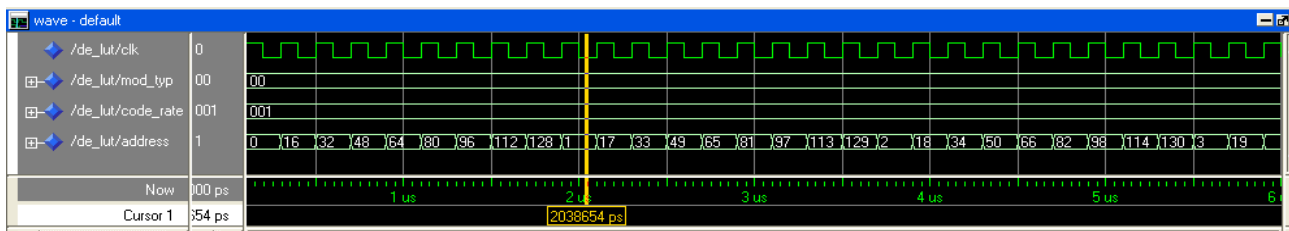

Figure 5. Simulation result showing initial addresses of Ncbps = 144 bits of QPSK modulation scheme

TABLE III. ROM\_00\_000

Input	Output	Input	Output
5	36	293	324
41	72	329	360
77	108	365	396
113	144	401	432
149	180	437	468
185	216	473	504
221	252	509	540
257	288	545	0

TABLE IV. DEVICE UTILIZATION SUMMARY

FPGA Resources / Parameters	Resource Utilization / Parameters in Spartan 3	Resource Utilization / Parameters in Spartan 3AN
Number of slices	633 out of 3584	626 out of 11264
Number of slice flip	56 out of 7168	41 out of 22528
Number of 4 input	1229 out of 7168	1205 out of
Number of bonded	16 out of 141	16 out of 502
Number of BRAMs	3 out of 16	3 out of 32
Number of GCLKs	1 out of 8	1 out of 24
Maximum clock speed	62.5 MHz	88.72 MHz
Power consumption	32mW	68mW

### VIII. CONCLUSION

In this paper, a novel technique to model the LUT based de-interleaver address generator for WiMAX system is proposed. A special relationship between the address LUTs has been explored and utilized to propose memory efficient design. The design is transformed into a digital hardware and is implemented on two different reconfigurable platforms. Comparative analysis with one of the existing implementation has been made to highlight improvement in the present work.

### REFERENCE

[1] A. Ghosh, D. R. Wolter, J. G. Andrews, and R. Chen, "Broadband wireless access with WiMAX/802.16: Current performance benchmarks and future potential," *IEEE Commun. Mag.*, vol. 43, pp. 129–36, Feb. 2005.

[2] U. S. Jha and R. Prasad, *OFDM towards Fixed and Mobile Broadband Wireless Access*, Artech House Publisher, London, 2007.

[3] I. Kuon and J. Rose, "Measuring the gap between FPGAs and ASICs," in *Proc. Int. Symposium on Field Programmable Gate Arrays*, Monterey, California, USA, ACM Press, New York, 2006, pp. 21–30.

[4] R. Asghar and D. Liu, "2D realization of WiMAX channel interleaver for efficient hardware implementation," in *Proc. World Academy of Sc. Engineering and Technology*, vol. 51, Hong Kong, 2009, pp. 25–29.

[5] "Local and metropolitan networks—part 16: Air interface for fixed broadband wireless access systems," *IEEE 802.16-2004*, 2004.

[6] "IEEE standard for local and metropolitan area networks—part 16: Air interface for fixed broadband wireless access systems—amendment 2," *IEEE 802.16e-2005*, 2005.

[7] B. K. Upadhyaya, I. S. Misra, and S. K. Sanyal, "Novel design of address generator for WiMAX multimode interleaver using FPGA based finite state machine," in *Proc. 13th Int. Conf. Computer and Information Technology*, Dhaka, 2010, pp. 153–158.

[8] *Xilinx Spartan-3AN FPGA Family Datasheet*. [Online]. Available: <http://www.xilinx.com>

[9] Xilinx. Using block RAM in Spartan 3 FPGAs. XAPP463. [Online]. Available: [www.xilinx.com](http://www.xilinx.com)



**Bijoy Kumar Upadhyaya** received the B. Tech degree in Electronics and Communication Engineering from North Eastern Regional Institute of Science and Technology (NERIST), Itanagar, India in 1998 and the Master of Electronics and Tele-communication Engineering from Jadavpur University, Kolkata, India in 2007. He joined Tripura Institute of Technology, TIT (erstwhile known as Polytechnic Institute), Narsingarh, Tripura, India as Lecturer in 2000. He is presently working as Associate Professor and Head in Electronics and Tele-communication Engineering Department of TIT, Narsingarh. He is member of IEEE, Life member of Institution of Engineers (India) and Institution of Electronics and Telecommunication Engineering. He has several publications in peer reviewed journals and international and national conferences. His research area is error control coding and its application in digital communication and digital system design using hardware description languages.



**Pranab Kumar Goswami** received B.E. Electronics and Telecommunication Engineering from Tripura Institute of Technology, Narsingarh, Tripura in 2012. He is presently working as Teaching Assistant in the same Institute. His area of interest includes communication engineering and electromagnetic theory.



**Dr. Salil K. Sanyal** ([s\\_sanyal@ieee.org](mailto:s_sanyal@ieee.org)) received his B.E.Tel.E., M.E.Tel.E. and Ph.D ( Engineering ) Degrees all from Jadavpur University, Kolkata – 700032, West Bengal, India in 1977, 1979 and 1990 respectively. He joined the Department of Electronics and Telecommunication Engineering, Jadavpur University as Lecturer in 1982 where currently he holds the post of Professor. He is the past Head of the Department of Electronics and Telecommunication Engineering of Jadavpur University. He has published more than 140 Research Papers in reputed peer reviewed Journals and International/National Conference Proceedings. He is the co-author of the Chapter "Architecture of Embedded Tunable Circular Microstrip Antenna" in the book entitled "Large Scale Computations, Embedded Systems and Computer Security" edited by FedorKomarov and Maksim Bestuzhev ( NY, Nova Science Publishers Inc. 2009 ). He was associated with many International Conferences as one of the members of Technical Program Committee. He has served as Reviewers of many journals of repute and also of several National/International Conferences. His current research interests include Analog/Digital/Radar Signal Processing, VLSI Circuit Design, Wireless Communication and Tunable Microstrip Antenna.